

STONEUK - ST-5005LZ

The Stoneuk ST-5005LZ is a robust LZ bracket made from high-strength aluminum, specially engineered for 500 kg electromagnetic locks installed on inward-opening wood or metal doors. Designed for stability and long-lasting performance, this bracket set provides a secure and precise mounting solution for both the magnet and armature plate. Its versatile design ensures compatibility with various door types, making it an excellent fit for advanced access control installations.

KEY FEATURES

- High-Strength Aluminum LZ Bracket
- Designed Specifically for 500 Kg Electromagnetic Locks
- Excellent Fit for Advanced Access Control Installations
- This Bracket Set Ensures Secure Mounting of the Magnet and Armature
- Offering a Stable and Professional Installation
- Universal Design Makes it Suitable for a Wide Range of Door Types

PRODUCT PARAMETERS

Opening Mode	90 Degree Door
Holding Force	500 KG
Finished for Shell	Anodized Aluminum
Material	High Strength Aluminum, Sandblast Finished
Dimension Z Bracket	190 X 70 mm
Dimension L Bracket	280 X 80 mm

DIMENSION

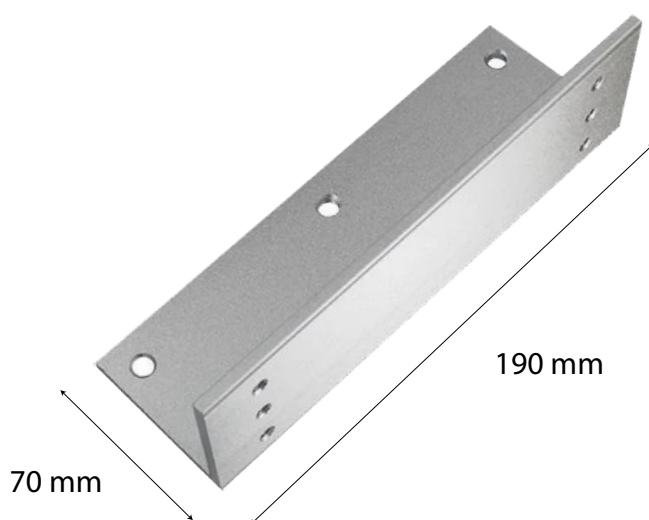
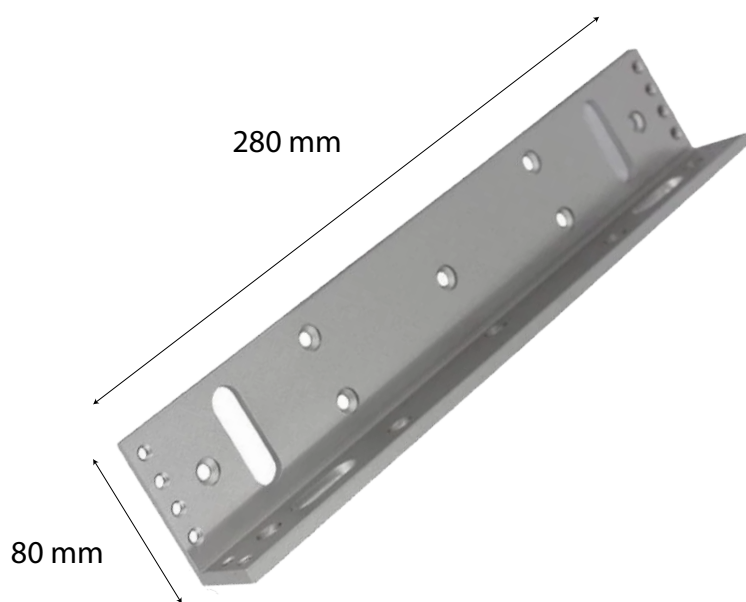

Get in Touch 

 +44 2080 773081

 info@thestoneuk.com

 www.thestoneuk.com