



STONEUK - ST-2805

The Stoneuk ST-2805 is a high-strength ELECTROMAGNETIC LOCK designed for secure access control applications. With a holding force of 280kg (600 lbs), it ensures reliable door locking for both indoor and outdoor environments. The lock features a built-in lock status sensor and LED indicator, providing real-time visual feedback and system integration capabilities. Ideal for offices, commercial buildings, and restricted areas, the ST-2805 offers a dependable solution for enhanced door security and monitoring.

KEY FEATURES

- Design Without Mechanical Failure
- High Strength Material, Anodized Aluminum Housing
- Anti-Residual Magnetism Designed
- Provides Reverse Current Protection
- Suitable For Wooden Door, Glass Door, Metal Door, Fireproof Door
- Collinear Load Test 280kg, 600pounds

PRODUCT PARAMETERS

Operating Voltage	12 / 24 V DC
Holding Force	280 KG (600 LBS)
Signal Output	Feedback Signal, LED, Time Delay, No/Nc/Com/+/-
Suitable for	Wooden Door , Glass Door ,Metal Door , Fireproof Door
Dimension	250 X 47 X 25 mm
Dimension of Armature plate	190 X 45 X 11 mm
Weight	2.1 Kg

DIMENSION

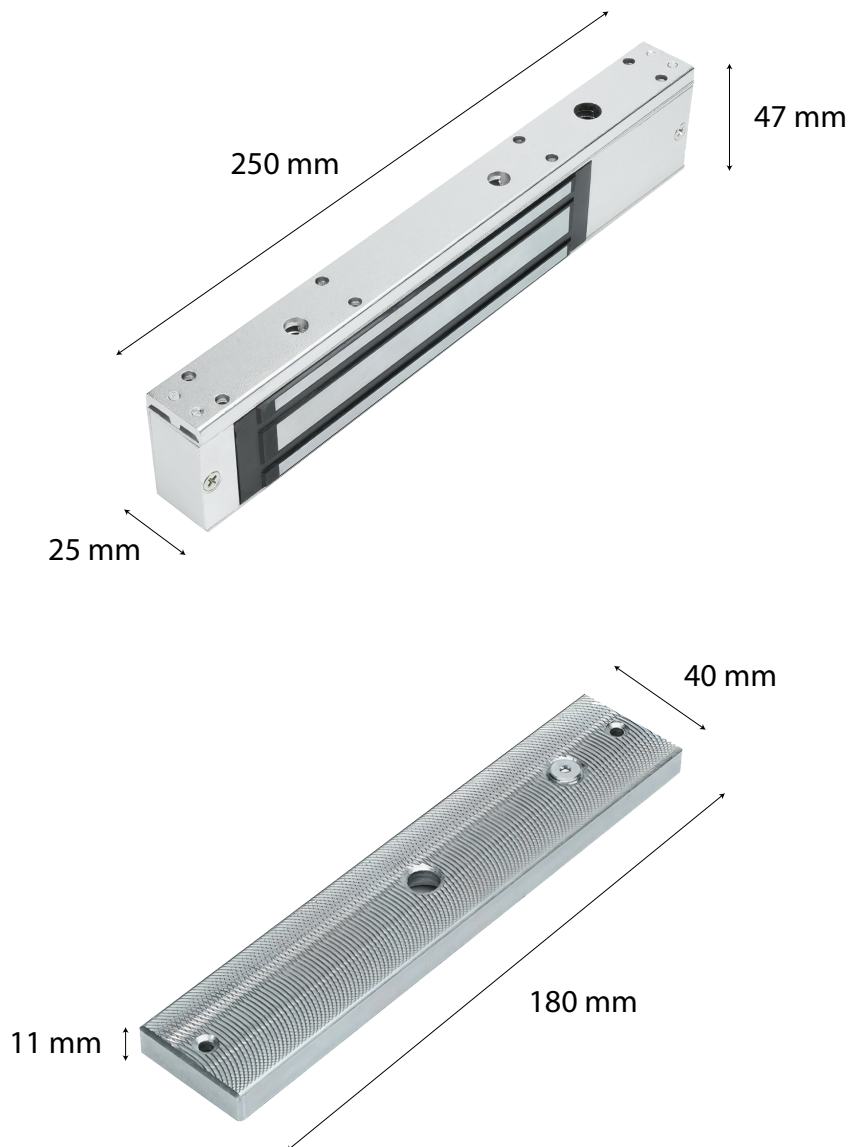

Get in Touch ▶

+44 2080 773081

info@thestoneuk.com

www.thestoneuk.com