



STONEUK - ST-2805LZ

The Stoneuk ST-2805LZ is a high-strength aluminum ZL bracket designed specifically for 280 kg electromagnetic locks installed on inward-opening wood or metal doors. Built for durability and reliability, this bracket set ensures secure mounting of the magnet and armature, offering a stable and professional installation. Its universal design makes it suitable for a wide range of door types, making it an ideal choice for access control systems.

KEY FEATURES

- High-Strength Aluminum ZL Bracket
- Designed Specifically for 280 Kg Electromagnetic Locks
- Built for Durability and Reliability
- This Bracket Set Ensures Secure Mounting of the Magnet and Armature
- Offering a Stable and Professional Installation
- Universal Design Makes it Suitable for a Wide Range of Door Types

PRODUCT PARAMETERS

Opening Mode	90 Degree Door
Holding Force	500 KG
Finished for Shell	Anodized Aluminum
Material	High Strength Aluminum, Sandblast Finished
Dimension Z Bracket	181 X 47 X 47 mm
Dimension L Bracket	252 X 47 X 28 mm

DIMENSION

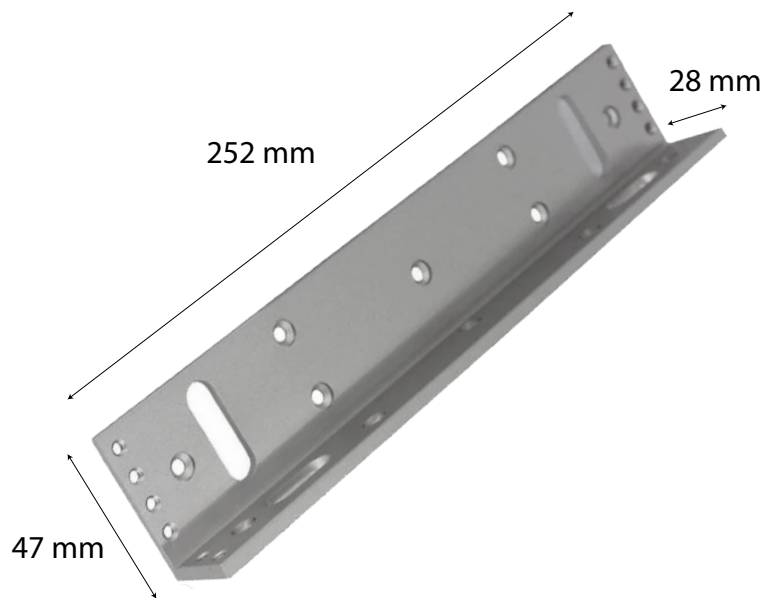

Get in Touch 

 +44 2080 773081

 info@thestoneuk.com

 www.thestoneuk.com